

**ASSEMBLY INSTRUCTION**  
**PUCH**  
**COFFEE TABLE**  
**ITEM CODE 85832**

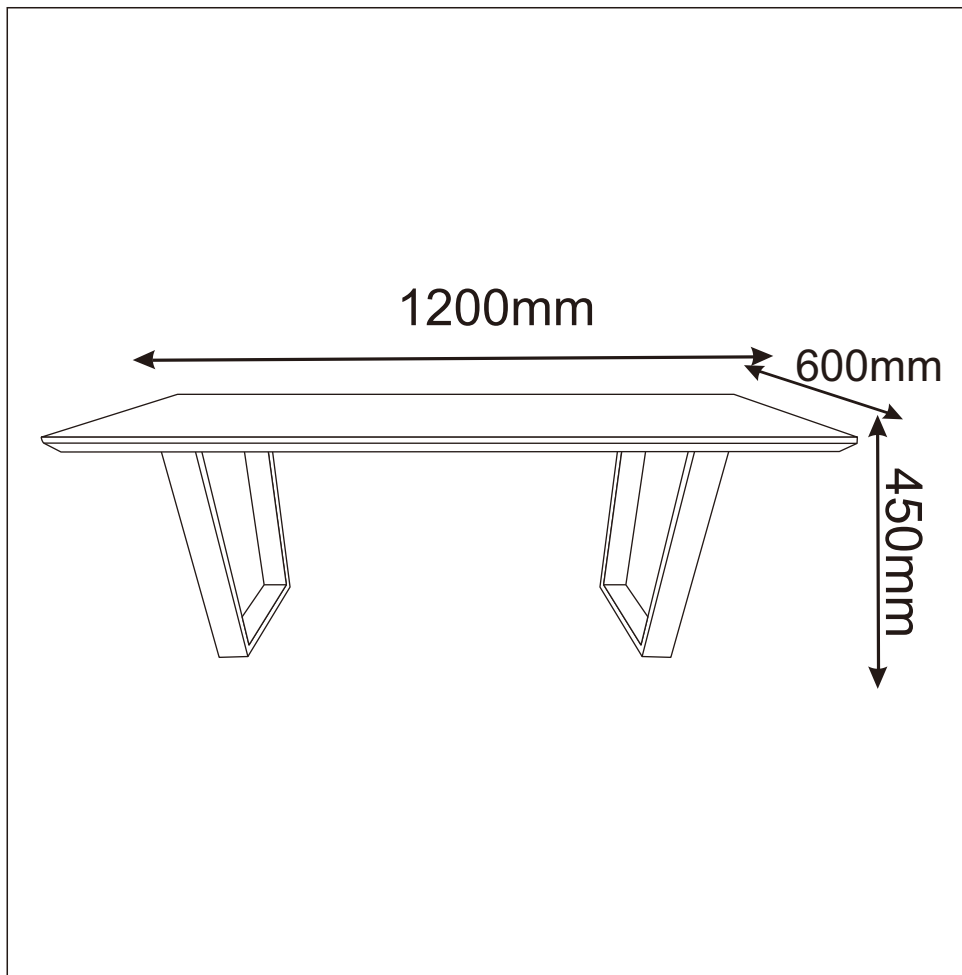

Imported by JWA Furniture Pty Ltd, Qld, Brisbane Australia.

For any assistance with assembly or for missing parts please refer to your receipt



# PRE-ASSEMBLY PREPARATION

## Before you start:

1. Choose a clean, level, spacious assembly area. Avoid hard surfaces that may damage the product
2. Take care when lifting. Product should be assembled as near as possible to the point of use
3. Ensure that you have all required contents for complete assembly
4. Always read the assembly instructions carefully before beginning assembly.
5. Keep all hardware parts and packaging out of reach of small children.
6. Do not over tighten the screws and bolts as this may damage the threads

		
Allow 10 min	For 2 people	Additional tools required

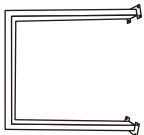
# PARTS LIST

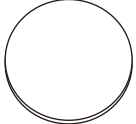
A	B	C	D	E
		 8x20mm	 M6	 Φ40mm
1	2	6	1	4

**STEP 1:**

- Turn over the table top (A) on a protected surface
- Put the table leg (B) on the top, tighten the screw (C) with Allen (D)
- Tighten the table feet (E)

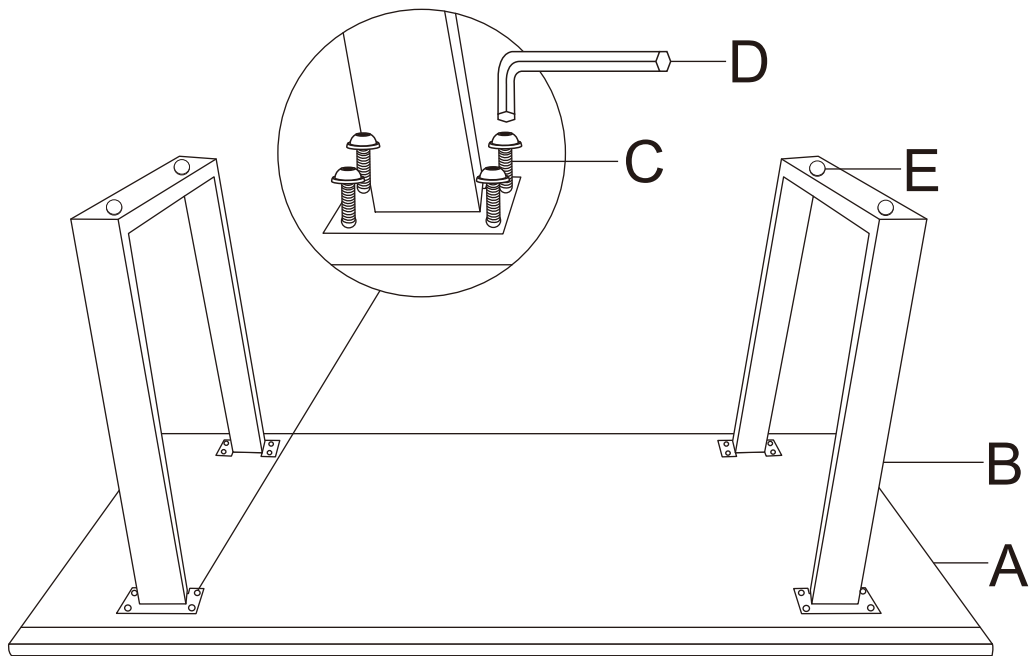

**ASSEMBLY IS COMPLETE**



## **To protect your furniture, we suggest the following:**

- Avoid placing your furniture in direct sunlight.
- Do not place furniture directly under windows.
- Do not place sharp materials (knife, fork, etc.) directly onto your furniture as sharp material may scrape and damage the finish.
- Do not place material with high temperature directly onto the surface of your furniture.
- Clean up spills quickly. Water left over a prolonged period of time may cause damage. Alcohol, perfume, nail polishes, aftershave and some medication may cause severe finish damage if not cleaned immediately.
- Use a clean, soft, dry, lint free absorbent cloth to clean your furniture. Do not use any detergent as they may contain ingredients that may react and damage the finish.
- NOTE: If the above care advise is not adhered to your product warranty may become void